

# User Manual

## PROFILE

### 200Z-RGBW

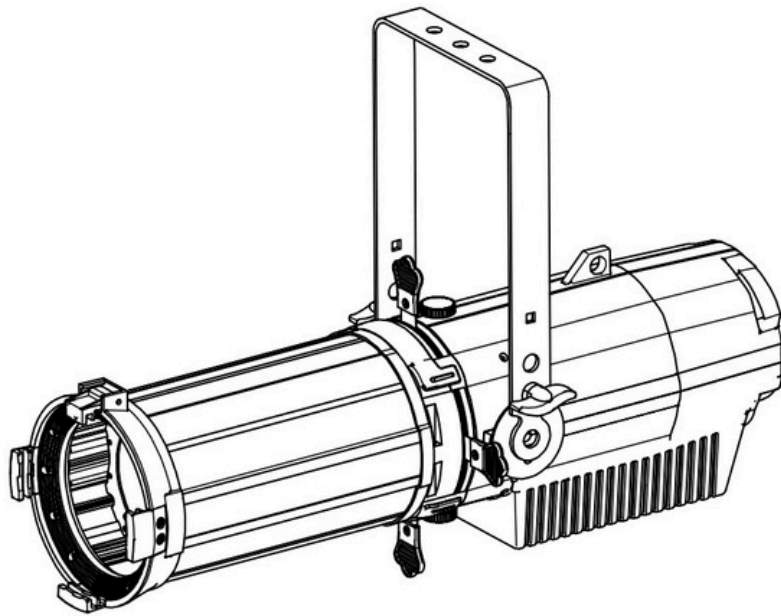

CE RoHS  IP20

# 1 SAFETY INSTRUCTIONS



## CAUTION

This device hasB elecfratr ethfuel wfaithc tyooruyr oinp epraetriofoensc.tW cithn ad ditainogne.r olnus o vrodltteagr etc  
to ensure a safea doapnegerarotuiosn e,l eitic tirsic ashbosckl uwtheelny tnoueccheinsgs wairryes flor the user to fo  
instructions and warning notes written in this user manual.



## IMPORTANT

Damages caused by the disregard of this user manual are not subject to warranty. The dealer will not accept liability for any resulting defects or problems.

If the device has been exposed to temperature changes due to environmental changes, do not switch it on immediately. The arising condensation could damage the device.

Leave the device switched off until it has reached room temperature.

This device falls under protection-class I. Therefore it is essential that the device be earthed.

The electric connection must carry out by qualified person. The device shall only be used with rate voltage and frequency.

Make sure that the available voltage is not higher than stated at the end of this manual.

Make sure the power cord is never crimped or damaged by sharp edges. If this would be the case, replacement of the cable must be done by an authorized dealer.

Always disconnect from the mains, when the device is not in use or before cleaning it.

Only handle the power cord by the plug. Never pull out the plug by tugging the power cord.

During initial start-up some smoke or smell may arise. This is a normal process and does not necessarily mean that the device is defective, it should decrease gradually.

Please don't project the beam onto combustible substances.

Fixtures cannot be installed on combustible substances, keep more than 50cm distance with wall for smooth air flow, so there should be no shelter for fans and ventilation for heat radiation.

If the external flexible cable or cord of this luminaire is damaged, it shall be exclusively replaced by the manufacturer or his service agent or a similar qualified person in order to avoid a hazard.

## 2 Unpacking

Thank you for choosing our PROFILE 200Z-RGBW. For your own safety, please read this manual before installing the device. This manual covers the important information on installation and applications. Please install and operate the fixture with following instructions. Meanwhile, please keep this manual well for future needs.

The PROFILE 200Z-RGBW is made of a new type of high temperature, slatlength of die-cast aluminum casing with nice outlook. The fixture is designed and manufactured strictly following CE & RoHS standards to comply with the international standard independently controlled and linkable with each other for operation. And it is applicable for large-scale live performances, theater, studio, nightclubs and discos.

The PROFILE 200Z-RGBW adopts 1PCS 200W COB LED (available for RGBW) which features high brightness and stability. Please carefully unpack it when you receive the fixture and check whether it is damaged during the transportation. And please check whether the following items are included inside the box:

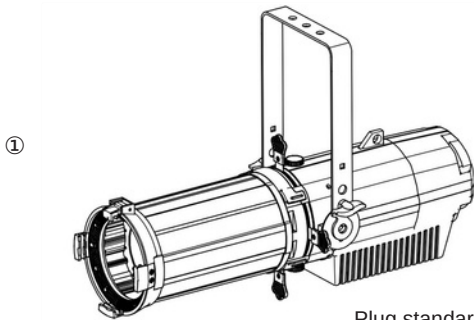

Plug standard: USA    EURO    UK



④

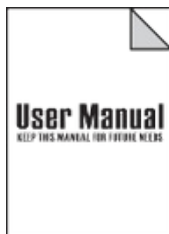

⑤

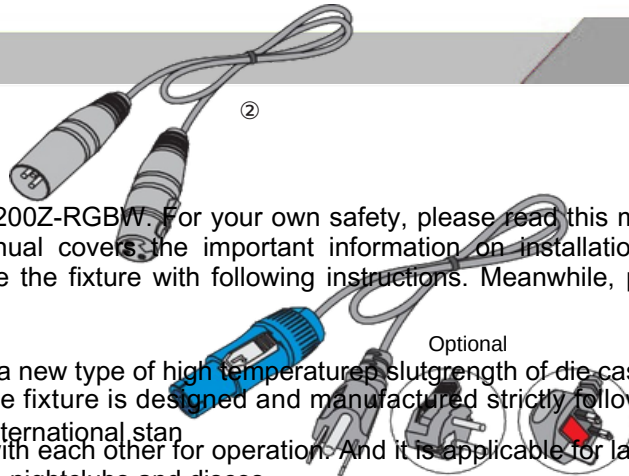

Optional

① PROFILE 200Z-RGBW	1PC
② DMX cable	1PC
③ POWER cable	1PC
④ POWER OUT	1PC
⑤ User Manual	1PC

① 4眼观众灯	1PC
② 信号线 电源	1PC
③ 线 电源输出	1PC
④ 接口 说明书	1PC
⑤	1PC

## 3 FEATURES

&

## SPECIFICATIONS

<b>Feature:</b>
*1*200W COB LED (RGBW)
*50,000 hours life time and low power consumption
*High quality optical system and field uniformity
*High contrast aspheric lens
*Beam Angle: 12°to 30° or 25°to 50°(Manual Zoom)
*Die casting aluminum housing design
*4 Metal spot cutting slots
*4 kinds of dimming curve
*Dimming Frequency: 500HZ - 25000HZ optional
*Strobe :1-25times/sec
*4/7 DMX channels
*Control Protocol: RDM / DMX , Master/Slave,Auto run and sound mode
*LCD with touch screen
*Low noise fan with copper liquid cooling system
*Working Temperature: -10°C~40°C
*IP20 protection rating
<b>Specifications:</b>
*Input Voltage:AC100-240V 50/60Hz
*Max.Power :200W
*Dimensions: 738(D)*187(W)*436(H)mm
*Packing Size(12°to 30°): 955(D)*330(W)*315(H)mm
*Packing Size (25°to 50°): 820(D)*330(W)*315(H)mm
*Net Weight: 11.46kg (12°to 30° ); 11.05kg (25°to 50°)
*Gross Weight: 14kg (12°to 30° ); 14kg (25°to 50°)

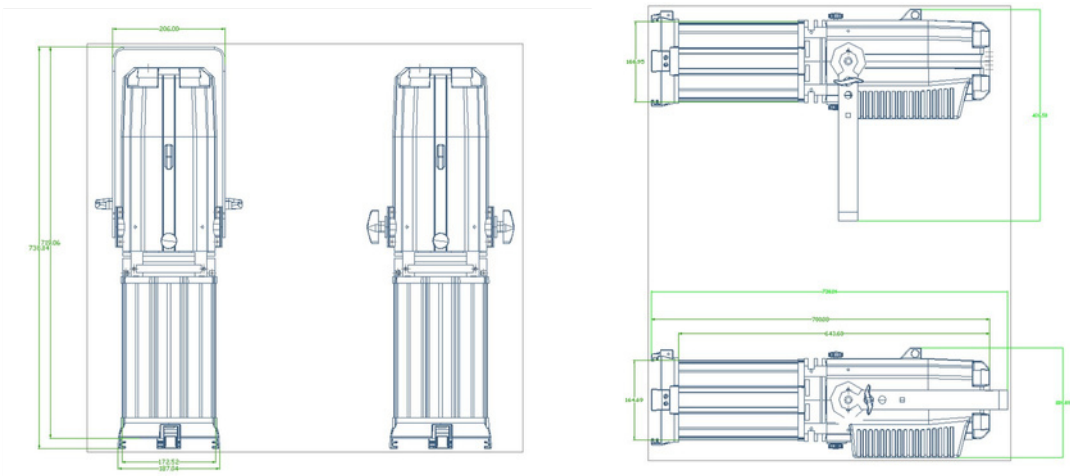

## 4 DMX-512 CONTROL CONNECTIONS

Connect the provided XLR cable to the female 3-pin XLR output of your controller and the other side to the male 3-pin XLR input of the moving head. You can chain multiple Moving head together through serial linking. The cable needed should be two core, screened cable with XLR input and output connectors. Please refer to the diagram below.  
DMX-512 connection with DMX terminator

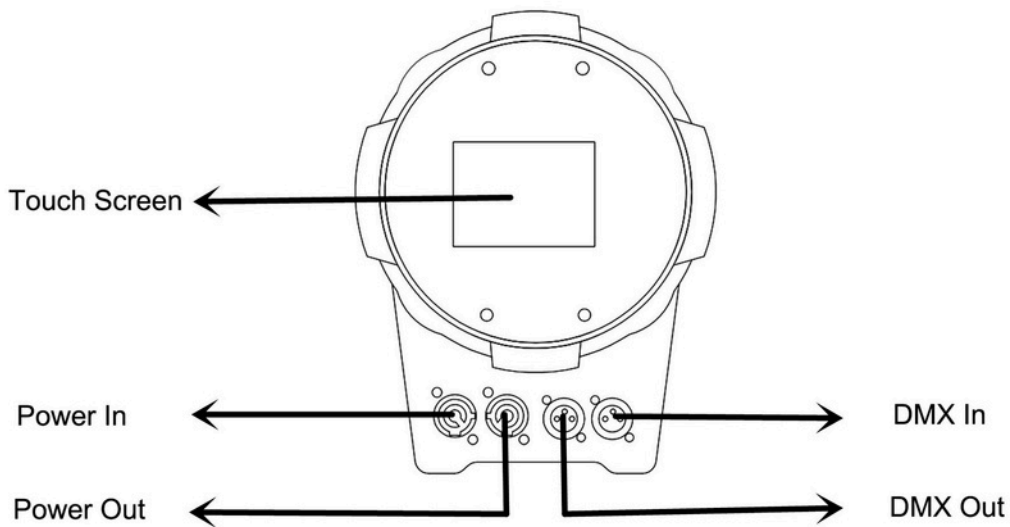
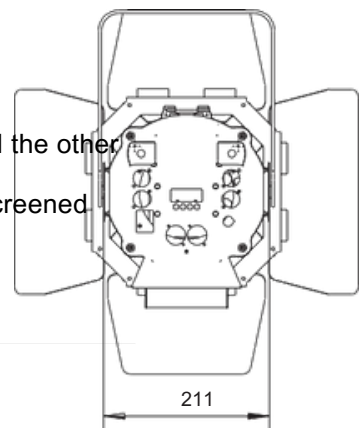

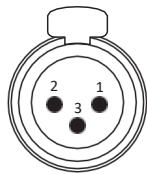
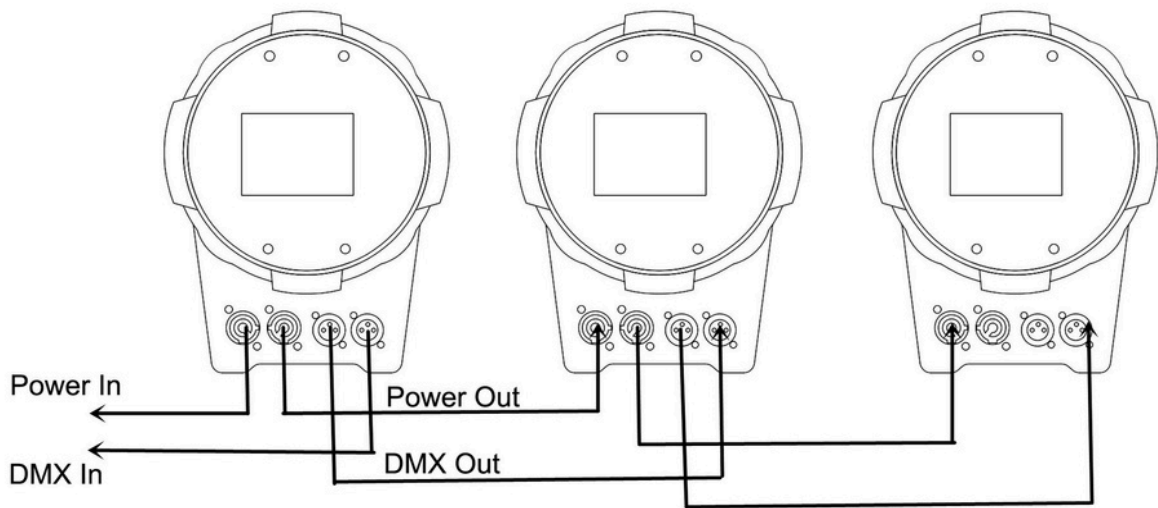

DMX Output  
3-Pin XLR

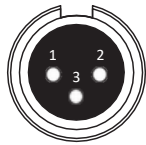

DMX Input  
3-Pin XLR

1:Ground  
2:Data(-)  
3:Data(+)

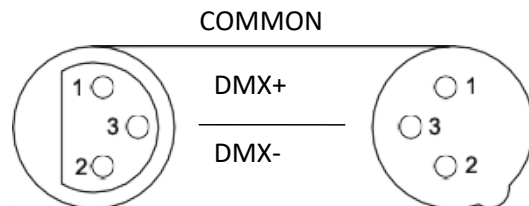

DMX512 Out  
3-Pin XLR

DMX512 In  
3-Pin XLR

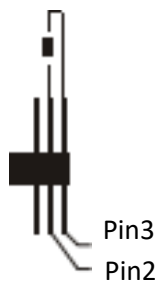
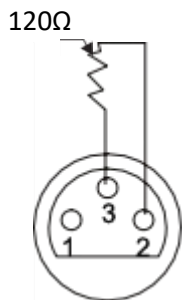

For installations where the DMX cable has to run a long distance or is in an electrically noisy environment, such as in a discotheque, it is recommended to use a DMX terminator. This helps in preventing corruption of the digital control signal by electrical noise. The DMX terminator is simply an XLR plug with a 120  $\Omega$  resistor connected between pins 2 and 3, which is then plugged into the output XLR socket of the last fixture in the chain. Please see illustrations below.

## 5 Product Feature

- 2 kinds of running model**
  - External control mode (Slave model)
    - DMX 512 controller control(2 kinds channel modes)
    - Master/salve model control (auto match the signal from controller and the Master light, no need to set by menu)
  - static mode (Master model)
    - It can fix any color without the controller ,also work this color with strobe
- Non-linear dimmer and linear dimmer**
  - The speed of dimmer can be set under the controller control
- Screen Protect**
  - It will enter blank screen without any operate on the keyboard in 30 seconds . Press any keys then it can quit screen protection.
- Temperature Protection**
  - It can be set to temperature protection mode
- Speed of the Fan**
  - The fan will start to work when the working temperature reach 40 degree, and the speed will be changed according to the change of temperature.
- Can be Reverse display**

### Multi-light working in the same time

When using controller to control multi lights to work in strobe, the controller just send the channel data . The strobe effect will be depend on each light itself . And please take attention for the follow situation:

1. There will be many situations make the lights are not synchronization in the beginning. (For example: the different time of opening the light , or different time of them connect to the controller) .In this case, you can change value of the controller( for example push 20 to 0, and back to 20), then it can be synchronization.

2. Due to crystal frequency of different lights are not the same exactly, so it may not be synchronization after long time.

3. If need to keep synchronization for long time, there are two ways to do so:

A. Using the controller to edit program make the strobe, auto run effect,then they must be synchronization.

B. Using the Maser/Slave model

## 6 Main Menu

### 6.1 Main Menu

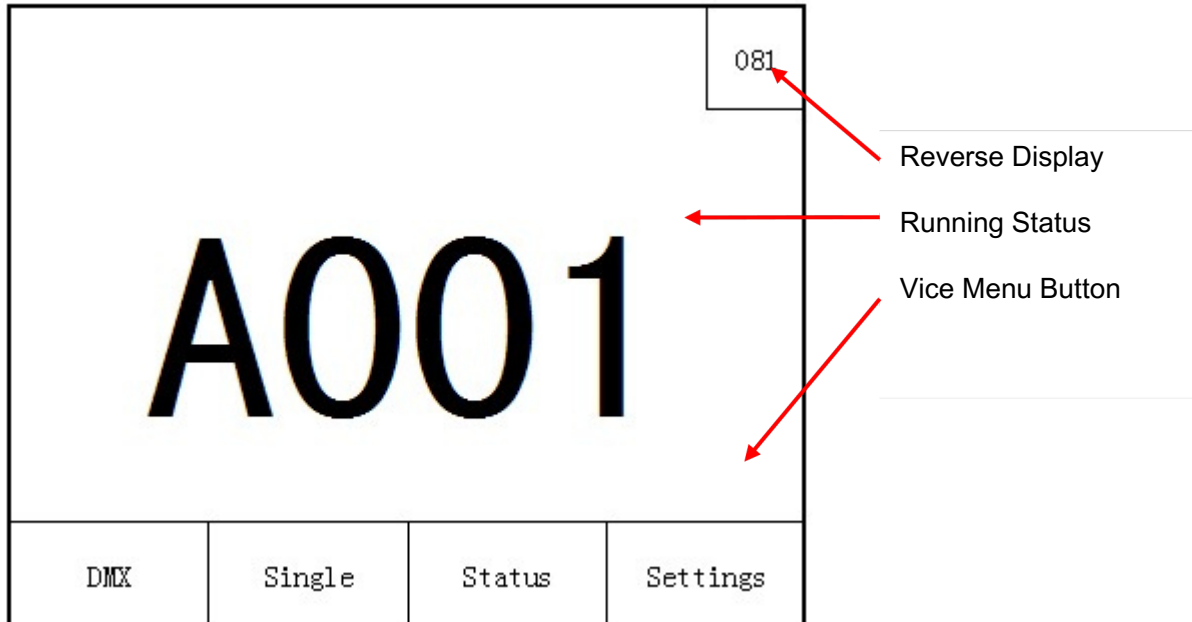

### 6.2 Operation Status

Mode	Display	Description
DMX Mode	Axxx	"A" stand for standard channel mode, "xxx" stand for ID address
	Dxxx	"D" stand for basic channel mode, "xxx" stand for ID address
Manual Mode	S-MC	"S" stand for stand alone mode, "MC" stand for "Mixed Color"



## **7** Vice Menu

### **DMX Settings**

<b>Menu</b>	<b>Operation</b>	<b>Option</b>	<b>Description</b>
DMX Start Address	Press key of "OK" enter to edit mode, press "UP" and "down" to edit the DMX address	1~512	
DMX Profile	Press key of "OK" change the DMX channel mode	7CH	Standard Channel Mode
		4CH	Basic Channel Mode

### **Single Mode Choice**

<b>Menu</b>	<b>Operation</b>	<b>Vice Menu description</b>
White Point	Press Key of "OK" to choose mode	Choose color temperature Choose
Quick Color	Same as before Same as before	inner setting color Choose the color
Mixed Color		and strobe setting

### **Status**

#### **Menu**

	<b>Description</b>
Software	Name of software
Version	Version
Temperature	Show the temperature of lighting fixture
DMX Status	With "OK" (Slave mode, with signal ) , " NONE" ( Slave mode , no signal ) , "Alone" (alone)

## Settings

Menu	Operation	Option	Description
Touch Screen Calibration	Touch screen adjust		
Dimmer Frequency	Change the dimmer frequency Change dimmer curve	500HZ .....	Each 100HZ for increase or decrease
		25000HZ	
		Standard Incandescent	
Dimmer Curve		Linear	
		Quick	
		45~95	
		10%~100% No screen	
Over Temperature	Temperature setting	protect or black screen from 0~ 60 second	Each 5 for increase or decrease
Backlight	Adjust the display brightness		Each 5% for increase or decrease
Backlight Timeout	Screen protect setting		Each 5 for increase or decrease
Load Factory Settings	Reset		

## 8 DMX CHANNELS

### Standard channel mode(7CH)

channel I	data	function	mark
1	0~255	dimmer color 1 color 2 color 3	
2	0~255	color 4 no effect speed of strobe	
3	0~255	(255 is the fastest) Empty Auto	
4	0~255	run Auto run 2-7 Auto run 8	
5	0~255	Empty sound control1	
6	0~10	sound control2	
	11~25		
	5 0~9		
	10~19		
7	.....		
	80-89		
	90-199		each 10 data is a program
	200-		
	219		
	220-		
	255		

### Basic channel mode(4CH)

channel	data	function
1 2 3 4	0~255	Color 1 (red)
	0~255	Color 2 (green)
	0~255	Color 3 (blue)
	0~255	Color 4 (white)

## **9** OPERATION & SPECIFICATIONS

·The PROFILE 200Z-RGBW is an LED profile light for on-site decoration purpose. ·Don't turn on the fixture if it's been through severe temperature difference like after transportation because it might damage the light due to the environment changes. So make sure to operate the fixture until it is in normal temperature. ·This light should be keep away from strong shaking during any transportation or movement. ·Don't pull up the light by only the head, or it might cause damages to the mechanical parts. ·Don't expose the fixture in overheat, moisture or environment with too much dust when installing it. And don't lay any power cables on the floor. Or it might cause electronic shock to the people. ·Make sure the installation place is in good safety condition before installing the fixture. ·Make sure to put the safety chain and check whether the screws are screwed properly when installing the fixture. ·Make sure the lens are in good condition. It's recommended to replace the units if there are any damages or severe scratch. ·Make sure the fixture is operated by qualified personnel who knows the fixture before using. ·Keep the original packages if any second shipment is needed. ·Don't try to change the fixtures without any instruction by the manufacturer or the appointed repairing agencies. ·It is not in warranty range if there are any malfunctions from not following the user manual to operate or any illegal operation, like shock short circuit, electronic shock, lamp broke, etc.

## **10** INSTALLATIONS

For added protection mount the fixtures in areas outside walking paths, seating areas, or in areas were the fixture might be reached by unauthorized personnel.

Before mounting the fixture to any surface, make sure that the installation area can hold a minimum point load of 10 times the device's weight.

Fixture installation must always be secured with a secondary safety attachment, such as an appropriate safety cable.

Never stand directly below the device when mounting, removing, or servicing the fixture.

From a ceiling, or set on a flat level surface (see illustration below). Be sure this fixture is kept at least 0.5m (1.5 ft) away from any flammable materials (decoration etc.).

Please ensure that the led profile spotlight is hung using the appropriate "C" clamp or half cheeseboro. A safety chain or cable should also be used as a secondary point of holding the fixture in case the clamp comes loose. Never hang the fixture without a safety chain or cable. There is an eye-bolt on the back of the fixture to which the safety chain or cable can be threaded through and then hung from the secondary point. Make sure the Gel frame (Gel holder) is clipped into position correctly and cannot come loose. If you are not qualified or have any doubts about hanging the led profile spotlight then do NOT hang it. Do not clamp the safety cable to the U bracket or clamp. That is not a secondary safety point. A secondary safety point is any point that will adequately hold the led profile spotlight if the "C" clamp or half cheeseboro fails. Then the safety cable would be the backup and stop the fixture from falling to the ground. So do NOT fix the safety cable to the same place that the "C"clamp is attached

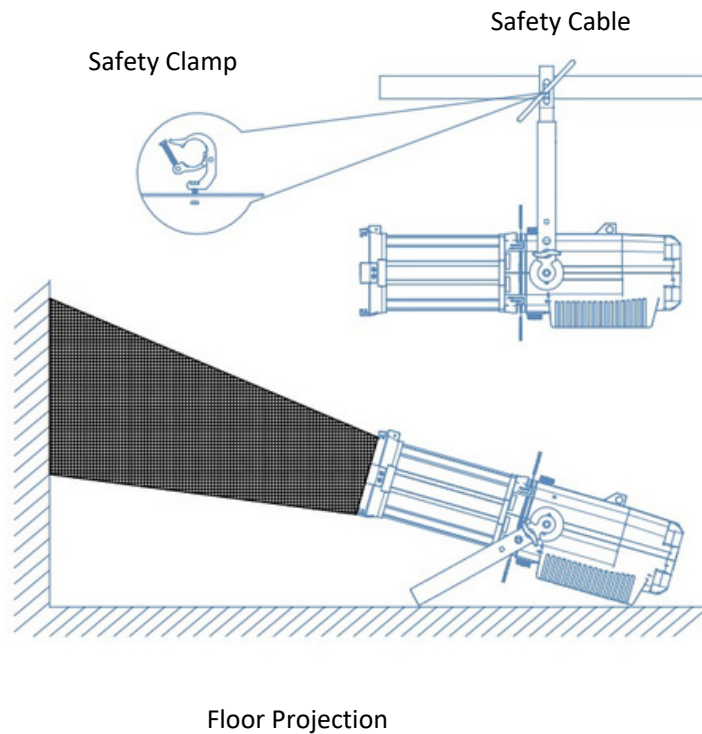

## 11 Cleaning and maintenance

Now ignoring maintenance and cleaning is very good way of creating problems "down the road" and many companies and installations do just that. However the net result is, no matter what the fixture, premature failure! Changing the oil in a car, most people do on a regular basis. So with the fixtures, regular maintenance is an excellent practice, if you want the fixtures to last. So what is the maintenance for the fixture?

### Clean the fans!

Turn off the led profile spotlight.

Using a small vacuum cleaner, suck the dust and "fur balls" out.

Do not use a can of  $\text{CO}_2$ . That will just blast the dust and dirt everywhere!

The fans keep the LED cool and keep the electronics cool too.

Without the fan working efficiently and dust free, the fixtures will fail and that will be a lot more costly than having someone

vacuum the fixtures on a regular basis.

How often should the fans be cleaned? It depends on where the fixtures are; in a very dusty atmosphere once a week. So

check the fans on a regular basis, they may not need cleaned every week but a quick "visual inspection" should be done.

The front lens should be cleaned so the light output is maintained.

The shutter blades sometimes require cleaning as well.

With the led profile spotlight turned off, use only a moist lint-free cloth. Never use alcohol or solvents to clean the fixture.

Never spray anything onto the fixture at the front or in any place on the fixture.

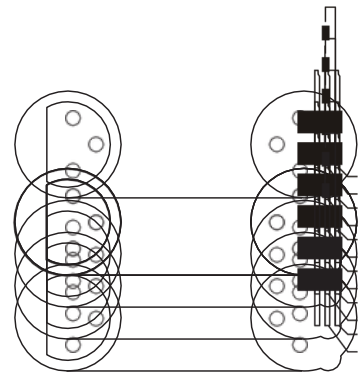



**LIGHTING**



+34 638626 631

[www.soundlightspain.com](http://www.soundlightspain.com)